

Description

DO-214AA/ P Series are low capacitance devices designed to protect broadband equipment such as VOIP, DSL modems and DSLAMs from damaging overvoltage transients.

The series provides a surface mount solution that enables equipment to comply with global regulatory standards while limiting the impact to broadband signals.



Features

Compared to surge suppression using other technologies, P Series devices offer absolute surge protection regardless of the surge current available and the rate of applied voltage (dv/dt). P Series devices:

- I Cannot be damaged by voltage
- I Eliminate hysteresis and heat dissipation typically found with clamping devices
- I Eliminate voltage overshoot caused by fast-rising transients
- I Are non-degenerative
- I Will not fatigue
- I Have low capacitance, making them ideal for high-speed transmission equipment

Part Number Code

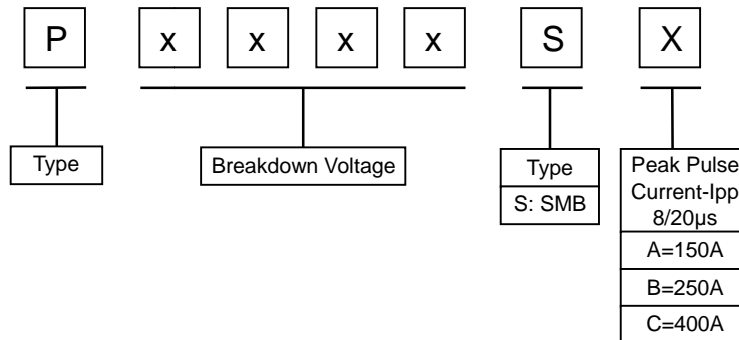

Surge Ratings

Series	Peak Pulse Current-Ipp(A)	
	8/20µs	10/1000µs
A	150	45
B	250	80
C	400	100

Thermal Considerations

Package	Symbol	Parameter	Value	Unit
 DO-214AA/SMB	TJ	Operating Junction Temperature	-40 to +150	°C
	TS	Storage Temperature Range	-40 to +150	°C
	RθJA	Junction to Ambient on printed circuit	90	°C/W



Electrical Characteristics

Type Number	V_{DRM}	V_S	V_T	I_{DRM}	I_S	I_T	I_H	C_J
	V	V	V	μA	mA	A	mA	pF
P0080SA	6	25	4	5	800	2.2	50	45
P0080SB	6	25	4	5	800	2.2	50	60
P0080SC	6	25	4	5	800	2.2	50	75
P0300SA	25	40	4	5	800	2.2	50	45
P0300SB	25	40	4	5	800	2.2	50	65
P0300SC	25	40	4	5	800	2.2	50	75
P0640SA	58	77	4	5	800	2.2	150	35
P0640SB	58	77	4	5	800	2.2	150	45
P0640SC	58	77	4	5	800	2.2	150	55
P0720SA	65	88	4	5	800	2.2	150	50
P0720SB	65	88	4	5	800	2.2	150	45
P0720SC	65	88	4	5	800	2.2	150	60
P0900SA	75	98	4	5	800	2.2	150	40
P0900SB	75	98	4	5	800	2.2	150	40
P0900SC	75	98	4	5	800	2.2	150	65
P1100SA	90	130	4	5	800	2.2	150	35
P1100SB	90	130	4	5	800	2.2	150	40
P1100SC	90	130	4	5	800	2.2	150	55
P1300SA	120	160	4	5	800	2.2	150	35
P1300SB	120	160	4	5	800	2.2	150	40
P1300SC	120	160	4	5	800	2.2	150	90
P1500SA	140	180	4	5	800	2.2	150	40
P1500SB	140	180	4	5	800	2.2	150	35
P1500SC	140	180	4	5	800	2.2	150	50
P1800SA	170	220	4	5	800	2.2	150	40
P1800SB	170	220	4	5	800	2.2	150	65
P1800SC	170	220	4	5	800	2.2	150	55
P2000SA	180	220	4	5	800	2.2	150	40
P2000SB	180	220	4	5	800	2.2	150	60
P2000SC	180	220	4	5	800	2.2	150	85
P2300SA	190	260	4	5	800	2.2	150	45
P2300SB	190	260	4	5	800	2.2	150	60
P2300SC	190	260	4	5	800	2.2	150	65
P2600SA	220	300	4	5	800	2.2	150	35
P2600SB	220	300	4	5	800	2.2	150	45
P2600SC	220	300	4	5	800	2.2	150	65
P3100SA	275	350	4	5	800	2.2	150	35
P3100SB	275	350	4	5	800	2.2	150	45
P3100SC	275	350	4	5	800	2.2	150	55
P3500SA	320	400	4	5	800	2.2	150	30
P3500SB	320	400	4	5	800	2.2	150	40
P3500SC	320	400	4	5	800	2.2	150	50



Type Number	V_{DRM}	V_S	V_T	I_{DRM}	I_S	I_T	I_H	C_J
	V	V	V	μA	mA	A	mA	pF
P4000SA	360	460	4	5	800	2.2	150	20
P4000SB	360	460	4	5	800	2.2	150	40
P4000SC	360	460	4	5	800	2.2	150	45
P4500SA	400	540	4	5	800	2.2	150	20
P4500SB	400	540	4	5	800	2.2	150	40
P4500SC	400	540	4	5	800	2.2	150	45
P5000SA	440	600	4	5	800	2.2	150	20
P5000SB	440	600	4	5	800	2.2	150	40
P5000SC	440	600	4	5	800	2.2	150	45

Notes:

V_{DRM} : Peak Off-state Voltage – maximum voltage that can be applied while maintaining off state.

V_S : Switching Voltage – maximum voltage prior to switching to on state

V_T : On-state Voltage – maximum voltage measured at rated on-state current

I_S : Switching Current – maximum current required to switch to on state

I_H : Holding Current – minimum current required to maintain on state.

I_{DRM} : Leakage Current – maximum peak off-state current measured at V_{DRM}

I_T : On-state Current – maximum rated continuous on-state current.

C_J : Off-state Capacitance – typical capacitance measured in off state.

Characteristics Curves

V-1 Characteristics

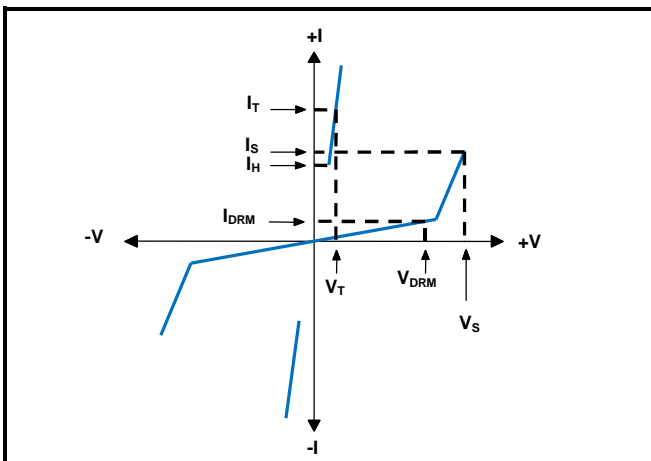

$t_r \times t_d$ Pulse Waveform

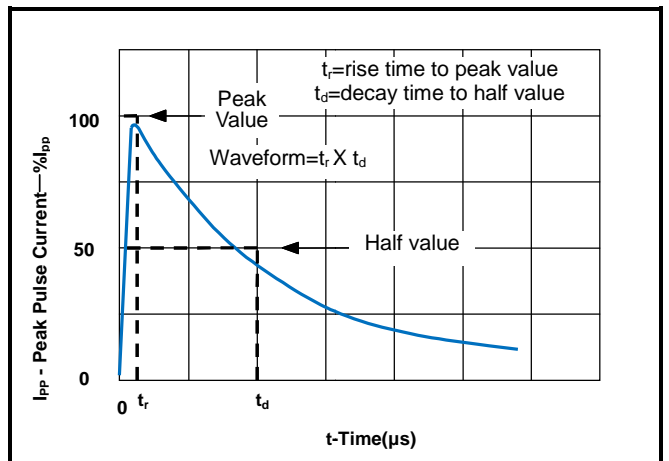

Normalized V_S Change vs. Junction Temperature

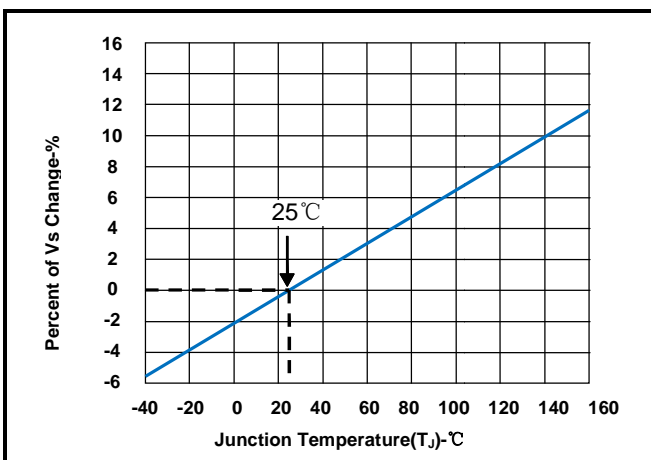

Normalized DC Holding Current vs. Case Temperature

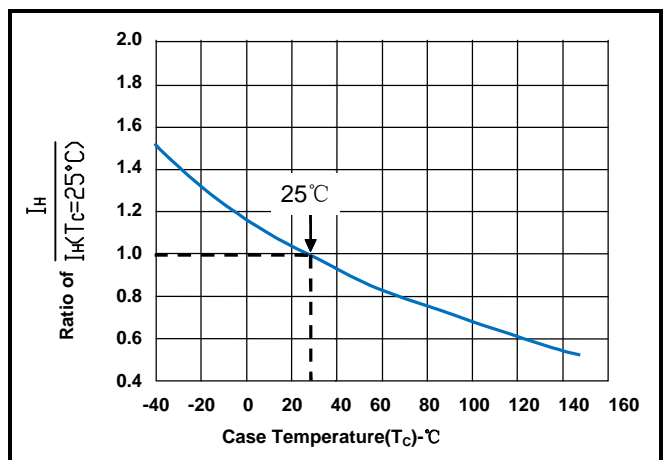

Soldering Parameters - Reflow Soldering (Surface Mount Devices)

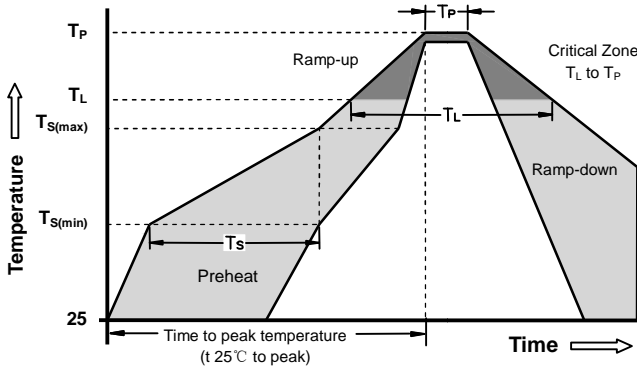

Reflow Condition		Pb - Free assembly
Pre Heat	- Temperature Min ($T_{S(min)}$)	150°C
	- Temperature Max ($T_{S(max)}$)	200°C
	- Time (min to max) (t_s)	60 - 180 Seconds
Average ramp up rate (Liquids Temp T_L to peak)		3°C/second max
$T_{S(max)}$ to T_L - Ramp-up Rate		3°C/second max
Reflow	- Temperature (T_L) (Liquids)	217°C
	- Time (min to max) (t_s)	60 - 150 Seconds
Peak Temperature (T_P)		260 +0/-5°C
Time within 5°C of actual peak Temperature (t_p)		20 - 40 Seconds
Ramp-down Rate		6°C/second max
Time 25°C to peak Temperature (T_P)		8 minutes Max
Do not exceed		260°C

Dimensions

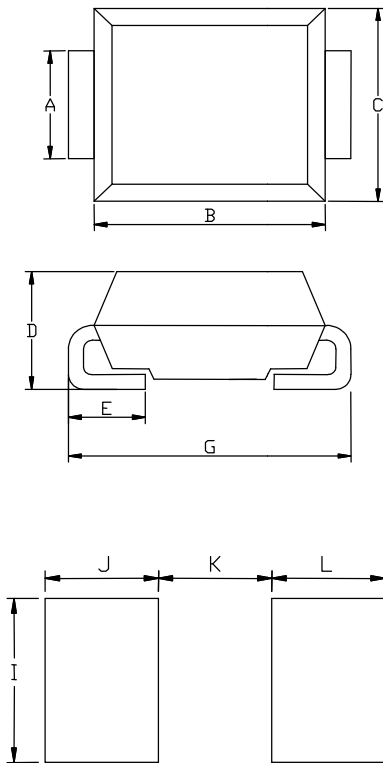

DIM	Millimeters		Inches	
	Min	Max	Min	Max
A	1.90	2.11	0.075	0.083
B	4.22	4.70	0.166	0.185
C	3.40	3.94	0.134	0.155
D	1.95	2.40	0.077	0.094
E	0.91	1.42	0.036	0.056
G	5.21	5.59	0.205	0.220
I	2.80		0.110	
J	2.00		0.079	
K	2.00		0.079	
L	2.00		0.079	



Taping and Reel Specifications

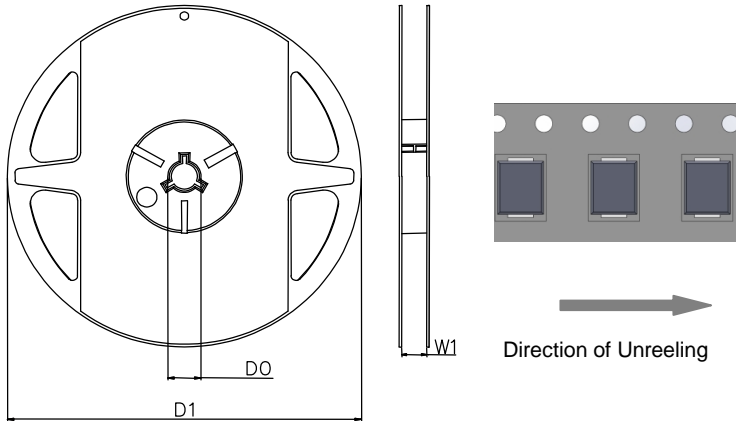
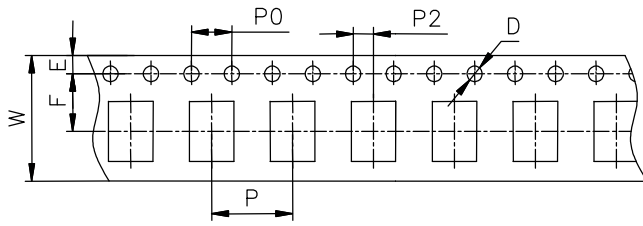

Symbol	Millimeters	Inches
W	12±0.3	0.472±0.012
P	8±0.1	0.315±0.004
F	5.5±0.1	0.217±0.004
E	1.75±0.1	0.069±0.004
D	1.55±0.05	0.061±0.002
P0	4±0.1	0.157±0.004
P2	2±0.1	0.079±0.004
D0	13.5±0.5	0.531±0.02
D1	Φ330±2.0	12.99±0.079
W1	16.0±1.0	0.63±0.039

Part Number	Component package	Quantity	Packaging option	Industry Standard
PxxxxSX	DO-214AA	2500	Tape&Reel-12mm tape/13"reel	EIA-481-1

